

Award Winning

TRIUMPH



Southern California
Triumph Owners
Association

Standard



Triumphs at the CCBCC
Oxnard car show

Vol. 34, No. 10 **In This Issue** **Oct - Nov 2017**

Contact List	2	Halloween Party Flier	7	Classified	30
Pilotage	3	John Nikas Book Signing	9	Monthly Events	31
Julian Drive Flier	4	TR6 Diff. Mount Repair	11	Calendar of Events	32
From the Editor	5	CCBCC Car Show	18	Membership Form	34
New/Renewed Members	6	Meeting Minutes	20	Hedke's Triumphs	back cover

SCTOA BOARD OF DIRECTORS

John Roberts, President ('19)	scouse2@aol.com	310-384-8491
Bob Jasper, Vice President	rbtjasper@gmail.com	562-866-4377
Tom Crowley, Secretary ('19)	tdcrowley@prodigy.net	626-274-1232
Rob Bowen, Treasurer ('19)	bowen6951@yahoo.com	909-899-5312
Allen Cox, Regalia ('18)	acoxelec@sbcglobal.net	323-753-5061
Jim Funkhouser, Web Master ('19)	Jims6t6@icloud.com	818-249-2407
John Roberts, Event Coord ('18)	scouse2@aol.com	310-384-8491
Open, Advertising		
Open, Raffle		

VOLUNTEER OFFICERS

Scott McKee, Newsletter Editor	sctoa-editor@att.net	714-925-7572
Paulette Caudill, Membership	paulette.caudill@att.net	310-322-2546
Jim Funkhouser, Email blasts	Jims6t6@icloud.com	818-249-2407
Bert Bennett, West Reg. VTR Chap Rep	Bennett.robert@att.net	949-566-4307
TBD, Newsletter Mailing		
Carl Miller, Triumphest Chairman	cmiller1948@charter.net	562-576-2630

TECHNICAL ADVISORS

Restoration, Race, Repair, Parts

Randall Young, TR2/3 and elect.	tr3driver@ca.rr.com	562-477-0311
Steve Dever, TR7/8 and others	sjdever@att.net	310-539-2851
Paul Smock, TR4/4A/Herald/other	smockracer@charter.net	562-431-8141
Open, TR6		
Gregg Cole, Spitfire and others	greggc101@yahoo.com	909-628-8169

REGIONAL BREAKFAST GROUP CONTACTS

John Gladysiewicz, Orange County	mijig@aol.com	
Dale Berman, Burb. Glend. Pas. SFV	Dalebermanphoto@earthlink.net	818-841-0200
Howie Margolies, South Bay	howiemargolies@aol.com	310-517-9891
Rob Bowen, Inland Empire	bowen6951@yahoo.com	909-899-5312

The TRIUMPH STANDARD is the bi-monthly publication of the Southern California Triumph Owners Association (SCTOA), Inc.

Editorial contributions, articles, photos and classified ads are welcome and may be sent to:

Scott McKee, 1517 Wood Lk., Santa Ana, CA 92705

sctoa-editor@att.net or s-mckee@att.net

For Triumph Standard Advertising contact:

Current rates are:

Business Card ads – (1/3 page)	\$.07/issue
1/2 Page ads	\$13/issue
Full Page ads	\$20/issue

Membership in SCTOA is \$35/Year Domestic; \$40/Year Foreign. Make checks payable to: SCTOA, P.O. Box 83820, Los Angeles, CA 90083 or call Paulette Caudill @ (310)322-2546 for a free sample newsletter

SCTOA is Incorporated and a member of the Association of California Car Clubs (ACCC); Western Vehicle Assoc. (WVA); Southern Calif. Council of Sports Car Clubs (SCCSCC); and is the largest official chapter of the Vintage Triumph Register (VTR) in the United States.

<http://www.sctoa.org/SCTOA/Welcome.html>

Front page photo by Dennis Lambert



Pilotage

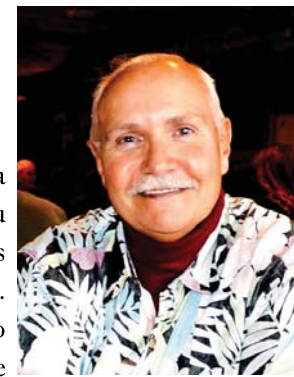

Last night I returned from Flagstaff after a wonderful few days with friends. As most of you know, Triumphests are the centerpiece of our clubs calendar year and the foundation of the clubs finances.

We knew that our club merger was going to cause a change in future rotations going from five to four hosting clubs. We also found that at this time, the San Diego club is unable to commit to hosting a Triumphest, that further reduces the host club number to three. A decision was made at the President's Meeting that after our Triumphest in 2019, we would begin skipping years. Starting in 2020, the even number years will be by-years with no Triumphest event. This will result in a six year rotation to the remaining clubs. While some of us may be disappointed in this decision, it needed to happen to protect our core members who work to present these huge events, we cannot thank them enough. They are the backbone of our clubs.

This change is not all bad news, in fact a lot of good can come from it. Not only the protection of our core members but the by-years will present opportunities to host smaller local events with other British Car Clubs or to attend the National Meets held by VTR and TRA.

Next years Triumphest will be in Sacramento hosted by the Triumph Travelers Sports Car Club, I would encourage you to consider attending because it promises to be a great event.

Our next Triumphest is 2019 in Santa Maria with Carl Miller as Chairman. While our numbers may be decreasing, our passion and enthusiasm isn't. With our combined memberships working together we can make Santa Maria an event to remember and hopefully the best one to date.

I would also like to thank the Triumph Sports Car Club of San Diego for their efforts, they have been a stalwart supporter of Triumphest hosting many events over the years. We look forward to working with them on future events.

Hoping to see you out and about in your Triumph.

Please Drive safely

John Roberts



<http://triumphest2018.org/>

Visit our award winning website: <http://www.sctoa.org>

Julian Drive

November 4-5

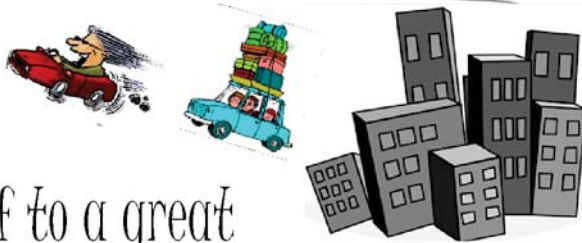

Treat yourself to a great
getaway weekend in Historic Julian!

meeting time 8:30 at Polly's Pies, 1799 Hamner Avenue,
Norco, leave time 9:00, bring warm clothes.

- Questions Call Rob: 909-899-5312
- RSVP email: bowen6951@yahoo.com
- For Julian Lodge reservations call: 800 542-1420

From the Editor



Many of you have already made the trip to Flagstaff for. Kate & I were supposed to be there with you. We had reservations, Registration #51 and plans. Kate was excited to see the sights I went to at the last Triumphfest in Flagstaff. I was looking forward to seeing how the Stag performed. Can anyone of you guess the total hours I spent on the road side the last trip with the Green Mile?

Sadly a double hitter of new equipment in transit for delivery and critical delivery requirements for a new customer has taken precedence. Sigh... even after taking the bribe of additional future vacation days and a new computer with a 32" screen - retirement looks better. 3 years and counting.

What's been keeping me from attending events has been working on the Stag's interior. Kate and I gave ourselves new leather seats for our third "leather" anniversary. Married life is good! In this process I had seat and back heaters installed as well; I'll be adding switches to the console. I have replaced the tan carpeting and any anything else that wasn't black. I'm now working on changing the color of my door panels to black; replacing the brown felt along the bottom has become quite challenging.

While I had the seats out I was able to take care of a few lingering problems with the electrical. I had previously found the radio was connected to the unswitched power buss. This had left the radio on all the time with the volume on low; thus draining the battery. I was able to correct it by installing a relay that switches the radio on with the ignition. I also found the radiator cooling fan was wired directly through the ignition switch; no wonder my other one melted down on me! The fan is now enhanced with the benefit of a relay that is part of a relay box with 5 other relays ready for use. I have a headlight upgrade in my near future so 4 of the 5 relays are already planned for.

What have you been up to? Is there anything you wish to share? Do you have an idea you wish to tell others about? I would like to hear from you - especially those who make it to Triumphfest. Did you attend another event where you took a few pictures? Please send them to me and Jim. If you can add a few words we will have a whole article. It's easier than you think. Let's see what you have to offer!

Scott

We Warmly welcome our New Members:

Steve Jenson ..1973 Yellow TR6 (He has a car, which has been garaged for 30 years and he needs help.)

Teryl & Olivia Loeffler 1973 Pimento Red TR6

Al Myers1973 Red TR6 (Alton's son)

(What are the chances that we would have three people join with the same car and the same year - 1973? Holy cow!)

We Appreciate Your Renewals - where would we be without you!:

Scott Aguilar1973 Green Spitfire 15, 1969 Midnight Blue GT6 & More

Larry & Arlene Bialecki 1967 White TR4A

Tony & Dina Draper 1969 Green GT6 &1979 Spitfire

Janice & Edward Etter 1958 White TR3A & More

John & Lucy Hickey 1965 Black TR4 IRS

Randy & Debbie Manes1973 Siena Brown TR6 (You are welcome)

Tony & Linda McGuyer 1959 Yellow TR3

Rebecca Mills1957 John Deere Green TR3

Charlie & Leeann Murphy 1974.5 TR6

Maria Rawald 1967 Red TR4A IRS

Frank & Marianne Wilson 1974.5 White TR6

Thank Paulette for our membership information.

Wanted!!!

Your e-mail address

TSCS would like your current e-mail for important bi-monthly

TCSC eNews

and other important reminders.

Stay aware, tune in to **TCSC eNews!**

Send an e-mail with your e-mail address to:

Paulette Caudill, Membership paulette.caudill@att.net

all e-mail addresses will be strictly for TSCS use only



HALLOWEEN PARTY

SATURDAY, OCTOBER 28

AT THE HOME OF CARL AND PATTI MILLER,
10837 FLORAL DRIVE,
WHITTIER.

CHILI COOK-OFF AND
COSTUME CONTEST
WITH PRIZES GOING
TO THE WINNERS.



TIME: 5:00 P.M.

RSVP:

CMILLER1948@CHARTER.NET

OR

562 576-2630

pageborders.org



**COMPLETE SERVICE
REPAIR & RESTORATION
FOR ALL YOUR TRIUMPH NEEDS!**

We Also Specialize In All **British Cars, BMW & Mercedes**

714.848.EURO (3876) · www.jpseuro.com

7271 Autopark Drive · Huntington Beach, CA 92648



Hi all,
 Here's a pic of the author, John Nikas (r), checking out my car at his "Rule Britannia" book signing. Next to John is our club's Vice President Bob Jasper.
 Regards, Mike McKittrick



RIMMER BROS
The Classic Parts Service

for this great marque

TRIUMPH

All the parts and accessories you will ever need

Stag
Spitfire
GT6
Dolomite
2000/2500
TR2-8
Herald
Vitesse

Free Catalogues

visit our new website
For prices and availability:
www.rimmerbros.co.uk

tel: +44(0)1522 568000
fax: +44(0)1522 567600
email: sales@rimmerbros.co.uk

Triumph House, Sleford Road, Bracebridge Heath, Lincoln, LN4 2NA, England

Parts service for Land Rover and MG Rover also available

LAND-ROVER
MG
Authorized Parts Distributor

TR6 Broken Differential Mount aka the Dreaded TR6 'Clunk' - An Alternative Fix

Earlier this year, I decided to refurbish the rear suspension on my 1974 TR6. The refurbish included the following new parts: uprated coil springs, polyurethane trailing arm bushings and spring pads, uprated lever shock links, universal joints, and differential mount bushings.

Removing all the components (trailing arms, springs, shocks, half-shafts) was rather straight forward and without issue. When I unbolted the half-axes from the differential, there was noticeable gear oil leakage at the differential. Crap. The differential also needed to be removed. I used a floor jack to support the differential, unbolted it from the mounts, and had a friend gently lower the jack while I balanced and eased it down for a smooth removal.

I cleaned the diff mounts with degreaser and there it was, the broken bracket dreaded on the right front mount. Yes, the broken bracket was the cause of that audible clunk when accelerating in 1st or 2nd gear. The recommended fix is to buy front and/

or rear diff mount repair kits, (which by the way are really replacement parts with beefier hardware of essentially the same design.) In severe cases, the repair is to remove



and replace the mount(s) entirely- all welded. This is well and good if the body is off the frame otherwise quite difficult with the body on. Even welding 2 side plates per bracket with the body on isn't easy. Body removal was not an option!

All of my diff mounts were in good shape except for that one broken bracket, so I really didn't need to buy any repair kits. In trying to figure out how to best fix and weld, I shared my dilemma with Bo Marron. He suggested a mechanical fix, a high strength nut and bolt solution. That intrigued me so we put our heads together and came up with a doable fix. We designed and fabricated a simple angle iron bracket assembly that bolts firmly to the broken mount and around the vertical stud.

TRIUMPH

TR2-TR3-3A-TR4-4A-TR6,7,8-TR250-Spitfire-GT6

SHOCK ABSORBERS: Each		CARBURETORS:	
Rear (Armstrong lever)	\$75.00	COMPLETE REBUILDING: disassembly, cleaning, bodies rebushed, new std. size throttle shafts, jets, needles, float valves, gaskets, O-rings. FLOW BENCH TESTED . . .	\$375.00 - \$415.00/pair
Heavy Duty Upgrade	\$10.00		
TR6 brake booster	\$175.00	Carb Bodies Rebushed and new throttle shafts . . .	\$85.00/ea
BRAKE MASTERS: Sleeved & Rebuilt		Prices shown are for Exchange or Yours Rebuilt. Core charges apply if items are ordered prior to (and are refunded after) our receiving old units.	
TR6, 7, 8, Spitfire.	\$125.00-\$145.00	Free Catalog - www.applehydraulics.com	
Spitfire, GT6 (1968-76)	\$175.00		
TR6 Booster	\$175.00		
TR3, 4, 4A (TR2 twin \$195)	\$95.00		
Caliper - (most models)	\$115.00-145.00		
Clutch Master	\$95.00		
Brake sleeving only, brass or SS	\$50.00-\$90.00		

APPLE HYDRAULICS
1610 Middle Rd., Calverton, NY 11933 • 631-369-9515, FAX: 631-369-9516
Toll Free: 800-882-7753
VISA, MC, DISCOVER, PAYPAL, COD

The design required 2 pieces of angle iron being attached to the underside (body side) of the diff mount bracket and bolted to each other, sandwiching the vertical stud that ultimately supports one corner of the differential.

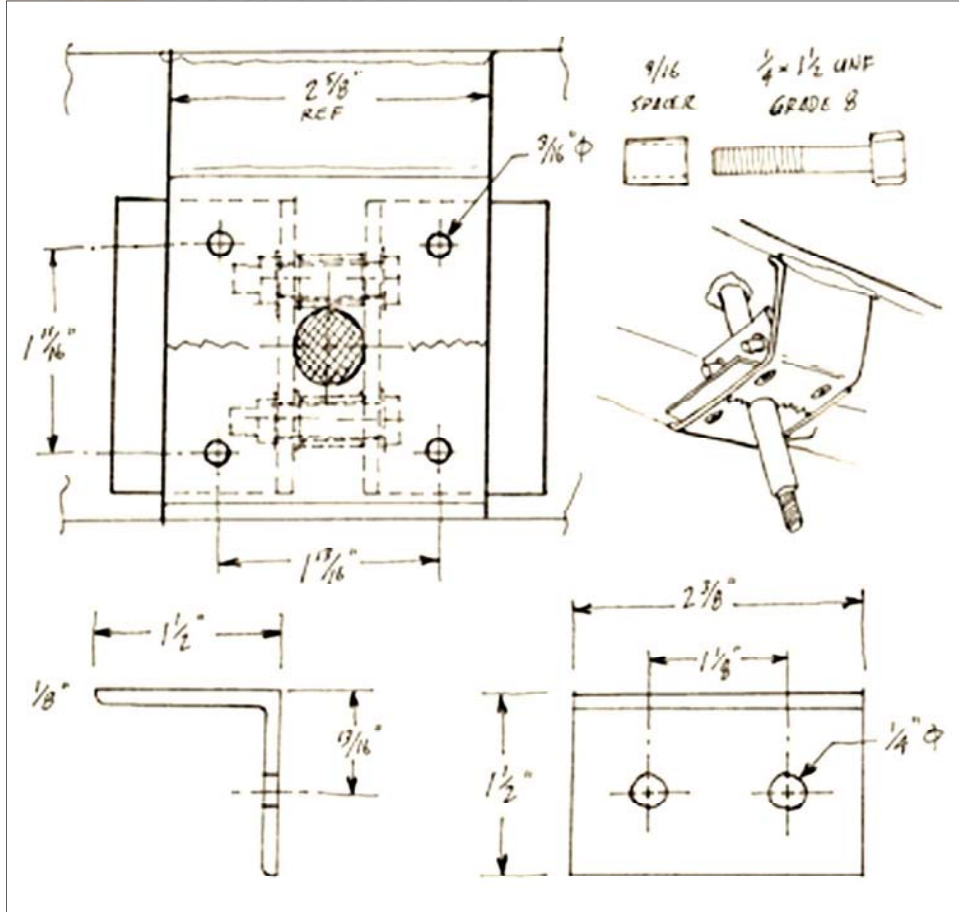
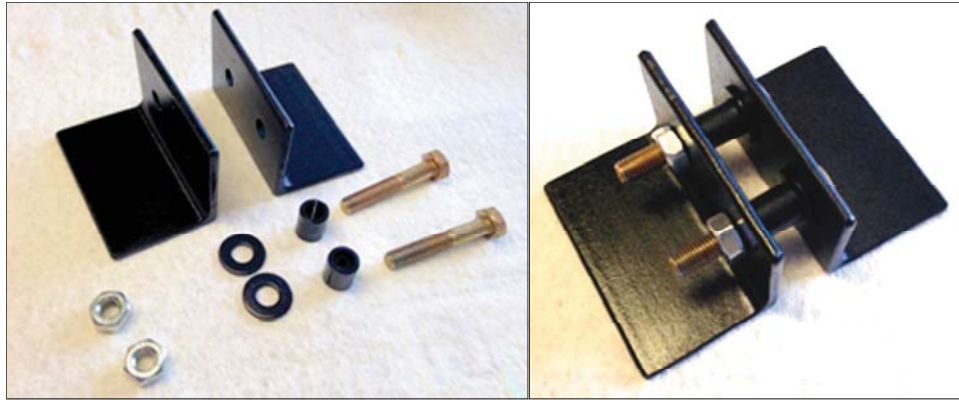

Four countersunk holes were drilled into the broken face of the diff mount and through the faces of the angle iron assembly. We used high strength flathead bolts and locking nuts to secure the face of the broken mount directly to the angle iron assembly.



Bo was right there helping out and instrumental in the success of this alternative fix.

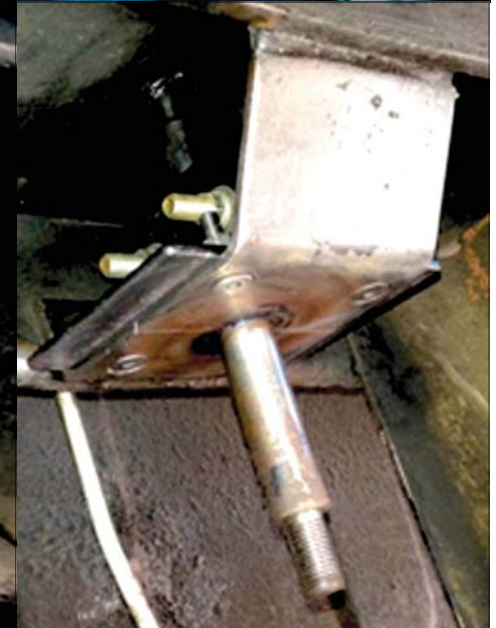

At this point, with the differential removed, I wanted to further strengthen the repaired diff mount and strengthen the front left mount as well. Using angle iron, I fabricated a couple of plates that could easily be welded to the

inboard side of each front diff mount.

My problem was, I don't weld. Rich Smirnoff, a fellow club member willingly helped me out. He brought over his MIG welder and did a great job of welding the two plates to the respective diff mounts.

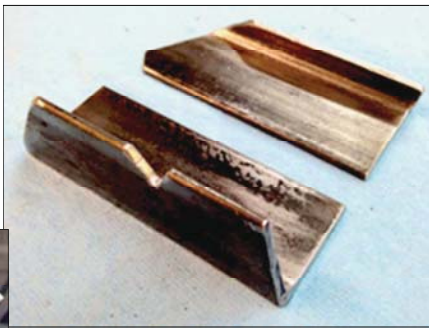

In addition, the design of the mechanical fix made the angle iron assembly protrude on both sides of the broken bracket by around 1/2". So, I asked Rich to weld the angle iron assembly to the side edges of the broken face. Once again, he did a great job which made the repaired diff mount even stronger.

I used an angle grinder to clean up the welded surfaces and gave all four mounts two coats of POR-15 rust preventive paint. Now I was able to continue the rear suspension refurbishing but with another problem.

Refurbishing the differential is beyond my capability. The choices were: pay and have it refurbished, buy a used rebuilt differential, buy a rebuilt unit

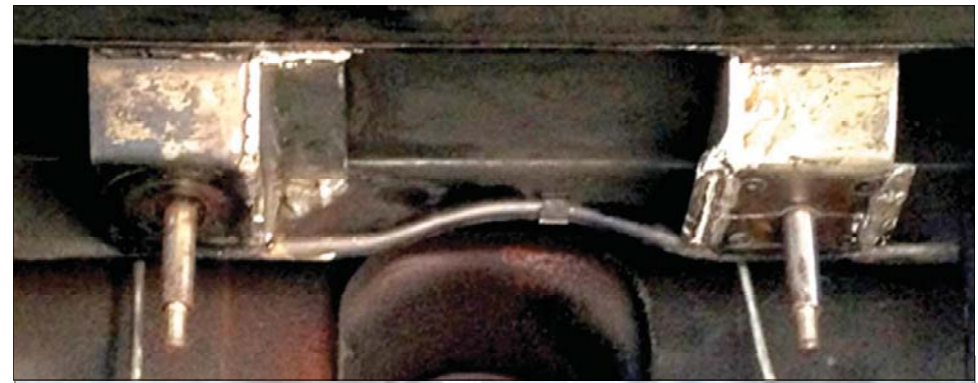

I decided to go with the Nissan R200 differential upgrade available from GoodParts. Hopefully I will never have to deal with an old school leaky TR6 differential again. The installation of the Nissan R200 is another story and might be worthy of a future article.

In summary, my diff mounts were in good shape except for the one that needed repair. The mechanical fix that Bo and I came up with worked well without having to take drastic measures like cutting holes from the interior or worse, remove the body.



Many thanks to Bo and Rich for their expertise and assistance.

Comments or questions?

Feel free to email me at mike.t.mckittrick@gmail.com.



The Roadster Factory



THE WORLD'S GREATEST BRITISH SPORTS CAR COMPANY!

At The Roadster Factory our goals are simply stated; to provide the best Triumph and MGB parts (most are factory original, OEM, or faithful reproductions) available, and to provide the best service in the British car industry!

TWO LEVELS OF TOLL-FREE ORDERING: TRF is proud of its unique dual-level telephone sales service.

Level One, (800) 678-8764 (for those who know TRF part numbers or who need to request one of our FREE catalogues) is available 7a.m. to 11 p.m. Mon. through Thurs. and 8 a.m. to 6 p.m. Fri. and Sat.

Level Two, (800) 234-1104 (for those who need part number assistance) is available from 8 a.m. to 9 p.m. Mon. through Thurs. and 8 a.m. to 6 p.m. Fri. and Sat.

TECHNICAL ASSISTANCE: (814) 446-4491 (for those who need advice in working on their cars), is available from 12:30 p.m. to 6 p.m. Mon. through Fri.

CUSTOMER SERVICE DEPARTMENT (800) 283-3723 (for those who need help with your business dealings with TRF), is available from 8 a.m. to 4:30 p.m. Mon. through Fri.

WORLD WIDE FAX ORDERING (814) 446-6729 is available 24 hours a day

WORLD WIDE WEB <http://www.the-roadster-factory.com>

THE ROADSTER FACTORY

328 Killen Road, Post Office Box 332, Armagh, Pennsylvania 15920

British Car Specialists

Since 1957

- Restoration
- Used Parts
- New Parts
- Service
- Repairs



**Austin-Healey
Triumph
MG**

209-948-8767

2060 N. Wilson Way
Stockton, CA 95205

www.BritishCarSpecialists.com



Litezupp Industries, LLC

The Cutting Edge in
Automotive Lighting Performance and Technology.



Be Seen! Not Sorry!

For detailed information visit us at:

www.litezupp.com

First in Quality and Customer Satisfaction

"Keep'em on the Road"

Parts & Accessories for MG, Triumph, Austin Healey and Sunbeam

VictoriaBritish.com



CCBCC CAR SHOW 2017

by Dennis Lambert

There is something to be said about skipping the drive to Oxnard in your TR3 and instead driving in the family station wagon.. Smooth quiet ride, air conditioning, stereo—but it's not the same! Attending a British car show without your British car is, well, kind of hollow. We had good excuses: our TR3 was sitting in the garage with a broken crankshaft, and we had our granddaughter staying with us for the week. So even if the TR3 was indeed running, we had three people to go, and three won't fit into a TR3 very well. But still, not the same without a Triumph! We did have a great time however, visiting with friends and eyeballing the cars. We also found a decent pizza place to eat lunch at in the vicinity, so, in the end, I'm glad we decided to make the drive. It turned out to be a fine Sunday afternoon. Cheers to all who actually drove their Triumphs and displayed. That's what makes the show what it is. Thank you! All in all, a good time. We are already planning to drive one of our TR's to the show next year. See you there!



Southern California Triumph Owners Association

General Membership Meeting Minutes - Date: Tuesday August 1, 2017

Number of Members in Attendance: 23

Meeting was called to order by John Roberts, President at 7:30pm.

- Meeting Opening: President Roberts welcomed the membership in attendance to the August club meeting.
- John shared that the club lost two members during the month of July. Dave Wellwood of Ventura and Joe Love of Texas. The club sends out its thoughts and prayer to the families of these members.

Old Business:

- John discussed the SCTOA/TRSC merger. A discussion was held to move the combined meetings to the second Tuesday of each month. The TRSC had voted overwhelmingly to make this change as it helps to avoid the holidays and the beginning and end of each month. John shared that the management of Geezers had been notified and approved the change, if the SCTOA voted in favor of it. John Roberts made a motion and asked for a show of hands to move the meetings starting in September to the second Tuesday of the month. There was 22 votes yes and 1 no vote. With the vote, the future combined club meetings will be held September 12, October 10, November 14, and December 12, 2017. Bob Cullum suggested that an email blast be sent out to all members as soon as possible. Jim Funkhouser was asked to update the club website.
- John reported that there are several names that have been suggested for the new club and newsletter. John shared that he would like to have the combined membership vote for the new name during the month of August via an email blast. The new club name is needed as soon as possible to change the checking accounts and club incorporation documents. John shared that his goal is to have all aspects of the club merger completed by the end of October. This will establish the new club going into the holidays, with the merger behind both of the old clubs.
- New suggested club names:
 1. Triumph Club Southern California
 2. Triumph United Southern California (Logo & name by Mike McKittrick)
 3. Triumph Sports Car Owners Association
 4. California Triumph Club (Logo and name by Mike McKittrick)
- New suggested newsletter names:
 1. Triumph Union
 2. Folded Jack
 3. Standard Triumph

New Business:

- John shared that he would like to start the raffle back-up and has several good items for this month. If anyone who like to volunteer for the Raffle Coordinator position or suggest any raffle prizes, please contact John Roberts.

Past Events:

- 7/11/17 - SCTOA White Elephant Auction. John reported that the auction was very successful and the club took in \$181.00
- 7/16/17 - Central Coast British Car Club's All-Brit Car Show. Bob Jasper reported that the show was smaller compared to ones in the past. Bridget and Dennis Lambert, and

Dennis Matthews who sold the Lamberts their TR3, were in attendance. Joe Salbego won an award in the TR6 class. The weather was beautiful.

- 7/18/17 - Third Tuesday Event at Ronald Reagan Library. John shared that 13 members attended. The museum was very nice and there was a Titanic exhibit. John shared that he loved Air Force One tail number 27000.
- 7/22/17 - Crystal Cove Drive and Picnic, hosted by Kate McKee. Mike McKittrick reported that the event was well attended and the weather was nice. He shared that this was the first event that he brought his wife, Karen to. She had a nice time.

Future Events:

- 8/10/17 through 8/13/17 - All Triumph Drive-In hosted by the Tyee Triumph Club, Portland Triumph Owners, and British Columbia Triumph Owners to be held at the Red Lion Hotel & Rocky Reach Dam, 1225 N Wenatchee Ave, Wenatchee Washington. For more details and information see website www.tyeeTriumph.org.
- 8/16/17 through 8/19/17 - Vintage Triumph Register National Convention to be held at Westin Princeton, 201 Village Blvd, Princeton, New Jersey. For more details and information see website www.vtr2017.org.
- 8/19/17 - Second Annual Drive-In Movie Night hosted by the Crowley family to be held at the Mission Tiki Drive-In Theater, 10798 Ramona Ave, Montclair. Meet at 6:15pm at McDonalds across the street. See club website for flyer and details. RSVP to Tom at 626-274-1232 or via email at tdcrowley@prodigy.net or Cody at 626-340-8617 or via email at codyccrowley@gmail.com.
- 9/9/17 - Glendora Drive hosted by Cody Crowley. Meet at 8:30am at Starbucks on Route 66 and Lone Hill in Glendora. Will be leaving at 9:00am and lunch to follow the drive. RSVP to Cody at 626-340-8617 or via email at codyccrowley@gmail.com.
- 9/21/17 through 9/24/17 - Triumphest 2017 hosted by the Desert Center Triumph Club to be held at the Little America Hotel, 2515 E Butler Ave, Flagstaff Arizona. For hotel reservations call 800-352-4386. For more details and information see website www.triumphest.com.
- John mentioned that the clubs are very lucky to have Zelda and George Wagner hosting the annual Christmas party. Since the party is held in Orange County, it was suggested that if someone in a different area would like to host the party please feel free to contact John Roberts.

Announcements:

- Patti Miller shared that Bob Muzio, who has been suffering with back problems, has been diagnosed with an infection of a vertebrae disk. He will be going through a six week antibiotic treatment. A card was passed around. Please keep him and his family in your thoughts and prayers.
- Jim Funkhouser shared that member Bob Prieve has been diagnosed with Alzheimer's disease. Please keep him and his family in your thoughts and prayer.

A raffle was held after all club business was concluded.

President Roberts adjourned the meeting at 8:35pm.

Southern California Triumph Owners Association

Board Meeting Minutes - Date: Tuesday August 1, 2017

Board Members present: John Roberts, Bob Jasper Tom Crowley, Rob Bowen, Allen Cox, Jim Funkhouser and Paulette Caudill.

Board members and volunteer officers absent: Scott McKee, Burt Bennett, and Carl Miller. Meeting was called to order by John Roberts President at 8:45pm

Old Business:

- A discussion was held regarding the club merger and adding Robert Levine as a signatory to the checking account in preparation of the SCTOA / TRSC club merger. Rob Bowen made a motion that Robert Levine will be added to the checking account signature card. John Roberts seconded the motion and the board unanimously voted in favor.
- A discussion was held if the club should have three or two board members on the signature card and leave past board member and Treasurer, Jim Kellar, on as a back-up. After discussion, Rob Bowen made a motion to remove Jim Kellar from the signature card. John Roberts seconded the motion and the board unanimously voted in favor.
- John Roberts discussed his goals to have all aspects of the club merger completed by the end of October. This will set the new club up going into the holidays, with the merger behind both of the old clubs. With the SCTOA membership voting to move the meetings to the second Tuesday of the month, the new joint meeting dates will be September 12, October 10, November 14, and December 12, 2017. John shared that the combined membership will vote via email for a new club and newsletter name during the month of August. The voting on a club logo will take place in the future once the club name has been chosen by the membership.

New Business:

- John Roberts discussed moving the position of Membership from a volunteer office position to a member of the board, with voting rights. John Roberts made a motion that the position of Membership be made a voting member of the board. Rob Bowen seconded the motion and the board unanimously voted in favor.
 - There was a discussion of moving and realigning the positions of Webmaster, Advertising, and Raffle Coordinator. After further discussion, no action was taken.
- With no other new or old business, President Roberts adjourned the meeting at 9:15pm.

Southern California Triumph Owners Association / Triumph Register of Southern California

Joint General Membership Meeting Minutes - Date: Tuesday September 12, 2017

Number of Members in Attendance: 39

Meeting was called to order by John Roberts, President at 7:33pm.

- Meeting Opening: SCTOA President Roberts and TRSC President Muzio welcomed the combined membership in attendance to the September joint club meeting prior to the historic club merger. Bob shared his thanks for all the cards and well wishes during his illness and reported that he is feeling much better, but is still on the mend.

Old Business:

- John shared the two new club names for a final vote of the membership, Triumph Club Southern California (TCSC) and Southern California Triumph Club (SCTC). Jim Funkhouser explained that the name Triumph Club Southern California (TCSC) came to him during the services of three fellow members in early 2017. When people spoke at the podiums they introduced themselves "I'm with the Triumph Club...." Jim suggested that TCSC had a better ring than SCTC. With that, John called for a membership vote for the new club name.

- The voting results were as follows:
 1. Triumph Club Southern California 39 votes
 2. Southern California Triumph Club 8 votes
- With the new club name of Triumph Club Southern California, John Roberts asked Mike McKittrick if he could work on a new club logo with Jim Funkhouser.
- At this time, John called for a membership vote for the new club newsletter. The results were as follows:
 1. Standard Tribune 27 votes
 2. Triumph Union 9 votes
 3. Folded Jack 5 votes

Past Events:

- 8/10/17 through 8/13/17 - All Triumph Drive-In hosted by the Tyee Triumph Club, Portland Triumph Owners, and British Columbia Triumph Owners held in Wenatchee Washington. No one from the club attended.
- 8/16/17 through 8/19/17 - Vintage Triumph Register National Convention held in Princeton, New Jersey. Bob Muzio reported that Herman van den Akker attended. The weather was great on the first day and wet for the rest of the event. Herman did not take their car. Herman reported, for Triumphest attendees, that there was construction on Highway 40 and to plan accordingly.
- 8/21/17 - Total Eclipse of the Sun - John Roberts shared that he was in Idaho to witness the total eclipse and that it was awesome. Dennis Lambert shared that they were in Oregon.
- 9/9/17 - Glendora Drive hosted by Cody Crowley. Cody reported a good turnout of 8 cars and 11 members for the drive. The weather and drive was great and ended with an enjoyable brunch.

Future Events:

- 9/21/17 through 9/24/17 - Triumphest 2017 hosted by the Desert Center Triumph Club to be held at the Little America Hotel, 2515 E Butler Ave, Flagstaff, Arizona. For hotel reservations call 800-352-4386. For more details and information see website www.triumphest.com.
- 9/24/17 - English Motors at Fairbrook Car Show located at Fairbrook Farms 4949 S Mission Rd, Fallbrook, CA. For more information and registration form check website www.englishmotoratfairbrook.org. Registration closes on 09/18/17.
- 9/30/17 - Campers Car Show and Breakfast hosted by First Baptist Church of Downey and Bruce Hearn. Located at 8333 2nd St, Downey, CA. Starts at 8:00am and ends at 1:00pm. Space for 100 cars. Registration cost \$20.00. For more information contact Bruce at 562-695-9088 or via email at bruce_hearn927@yahoo.com
- 10/5/17 through 10/8/17 - The Austin Bantam Society 49th Annual Trophy Meet in Monrovia, CA. Car show at the Santa Anita Racetrack on 10/7/17. For more information see website <http://historywithheart.com/abs/absnews.html>.
- 10/14/17 - Car Hop Night at Bob's Big Boy located at 4211 W Riverside Dr, Burbank. Time 4:00pm to 7:00pm. RSVP to Dale Berman at 818-841-0200 or via email at daleberman-photo@earthlink.net
- 10/21/17 - El Monte Children's Day Parade. Cars needed to transport parade dignitaries. Release and entry forms can be found on club website in the near future. For information and RSVP, contact Cody Crowley at 626-340-8617 or via email at

codyccrowley@gmail.com.

- 10/21/17 - Falling Leaf Drive hosted by Bob Muzio. Event is in question at this time. Bob will send out information if the event will be held.
- 10/28/17 - Halloween Party hosted by Patti and Carl Miller. Time: 5:00pm at 10837 Floral Dr, Whittier. Chili cook-off, costume contest, and more. Flyer is on the website. RSVP: Phone 562-576-2630 or email: cmiller1948@charter.net
- 11/4/17 through 11/5/17 - Julian Drive hosted by Rob and Bonny Bowen. Meeting time 8:30am at Polly's Pies at 1799 Hammer Ave, Norco. Leaving at 9:00am. Rob reported that there are still rooms open Please call lodge for reservations at 800-542-1420. RSVP email: bowen6951@yahoo.com or phone 909-899-5312.

Announcements:

- John mentioned that the club is still looking for a Raffle Coordinator and Advertising Coordinator. If interested please contact John at 310-384-8491 or via email at scouse2@aol.com.
- John shared that the 2017 Club Christmas Party location has not been yet confirmed. We are looking for a more central location. If anyone is interesting in hosting the 2017 Christmas Party please contact John at 310-384-8491 or via email at scouse2@aol.com.
- At this time John introduced Burt Bennett, VTR Western Region Director to speak about the Vintage Triumph Register. The Vintage Triumph Register (VTR) is a North American Triumph car club of over 2,800 Triumph owners and enthusiasts supporting and showcasing all models of Triumphs. Their award-winning VTR web site has been assembled through the co-operative efforts of many VTR members to make these pages a current and accurate resource for Triumph enthusiasts worldwide. The popular forum: The Triumph Forum, is hosted by VTR and is open to all Triumph enthusiasts, members and non-members alike. Not only will you find expert advice there, but you can post questions and get answers that will be most helpful in your enjoyment of these fun-to-own automobiles. VTR publishes a bi-monthly magazine, The Vintage Triumph, which is filled with valuable historical and technical articles and industry news. In addition to the magazine, membership in VTR also includes: access to VTR's staff of volunteer vehicle consultants, various VTR Triumph car club regalia, low-cost collector car liability insurance to members at costs far below regular insurance rates, an annual convention, hosted each year by one of VTR's many local chapters. If interested in joining or for more information contact Burt Bennett at 949-566-4307, via email at bennett.robert@att.net or check out the VTR website at <http://vintagetriumphregister.org>.

A raffle was held after all club business was concluded.

President Roberts adjourned the meeting at 8:21pm.

Southern California Triumph Owners Association

Board Meeting Minutes - Date: Tuesday September 12, 2017

Board Members present: John Roberts, Bob Jasper, Tom Crowley, Rob Bowen, Allen Cox, Jim Funkhouser and Paulette Caudill.

Board members and volunteer officers absent: Scott McKee, Burt Bennett, and Carl Miller.

Meeting was called to order by John Roberts President at 8:34pm

Old Business:

- John shared that his focus is in completing the club merger by the end of November. He asked that Rob Bowen and Rob Levine work together to combine the treasuries. Rob Bowen shared that they are working towards that goal, but it also depends on meeting together, as both live at opposite sides of the club territory. He also asked that Paulette Caudill and Heide van den Akker work towards merging the membership files.
- John shared that the latest newsletter mailing streamlined the process and will save money for the club in the future. John will allow editors Scott McKee and Dennis Lambert to finalize the transition and final copy of each club newsletter. John plans to investigate the postal costs for non-profit organizations with the post office to see what needs to be done for the club merger. John shared that the current printer, who did an outstanding job on the last SCTOA newsletter, is the same printer that the TRSC is currently using. The printer that was suggested by Liz Rodriguez did not work out. There was a lengthy discussion about the newsletter cost versus club membership and dues, as the last bill was \$200.00 higher than recorded in the past per Rob Bowen. Another point shared by John Roberts was that the club will be hosting Triumphfest in 2019. With the ongoing calendar discussions of future Triumphfest's, with the regional club President's, it could be another six years before the club would host another event. Triumphfest is the biggest fund raiser for the club so newsletter costs must be kept in check.

New Business:

- President John Roberts explained that there are nine board positions, according to the SCTOA By-Laws. The positions are as follows: President, Vice President, Treasurer, Secretary, Membership, Webmaster, Regalia, and two open seats that can be appointed by the board. John made a motion that with the club merger coming to a close that Bob Muzio and Robert Levine from the Triumph Register of Southern California (TRSC) be appointed to the board of the SCTOA. The motion was seconded by Rob Bowen and was approved by all members present.
- John Roberts shared that the SCTOA currently has six Lifetime Members. They are: Steve Oertwig, Bernie Demarkey, Bill Burroughs, Paul Smock, Paulette Caudill and Tom Quinn (deceased). The board of the TRSC has requested with the merger that six members are to be awarded Lifetime Membership for the contributions made to the TRSC. They are: Steve Hedke, Bob Jasper, Dennis Lambert, Bob Muzio, Marty Lodawer and Mario Gottuso.
- Bob Jasper shared that the TRSC in the past had created and sold a club calendar featuring member's cars and dates of upcoming events as a fundraiser. Bob has been asked with the merger if the calendar would be continued. It was suggested by the board that if someone is interested in designing and taking on the work that the board would be interested in continuing the calendar. Bob mentioned he has someone in mind and would speak to that person.

Announcements:

- John Roberts shared that the club planning meeting for 2018 will be held at his home on December 9, 2017 at 10:00am, barring any volunteers to hold the meeting elsewhere.

With no other new or old business, President Roberts adjourned the board meeting at 8:56pm

Classifieds

Cars & Parts for Sale

Our classified section is available to anyone (members and non-members) who has a Triumph car or parts for sale. We will also list TR cars or parts wanted. There is no charge for this service. It is helpful to send a photograph of your items for sale. Your classified ad will also be posted to our web page.

The best way to offer your car or parts for sale is to send the information to our newsletter editor s-mckee@att.net and your information will be printed here.

Your ad will run for two issues, then will be removed from the system. If you sell your car or parts, please contact the editor so your ad can be removed, and you will not be annoyed with calls after your items are sold.

1976 TR6 Original unrestored condition. Immaculately maintained for 41 years. Suspension, cooling and braking systems rebuilt and upgraded. Carbs just rebuilt and has passed smog. Factory hardtop and overdrive. Must see and drive to appreciate. A beautiful survivor. \$18,000 OBO. Jerry Davis 949-433-6648; jld2080@cox.net



1961 TR3A. Approximately 88,000 original miles. Four speed, no overdrive. New black top never installed, side curtains, some spare parts, no rust. Some chrome need redone. Repaint and upholstery in 1991. Second registered owner 26 years. Have some paperwork from original owner in San Diego. Lots of photos if interested. The car is in Hermosa Beach. \$16k, OBO.

Tom, pilot4112@aol.com 310-293-1490



1973 TR6 pimento Many upgrades. HVDA 5 speed trans. Tube rear shocks installed by Britalia, electronic ignition, hi torque starter, Toyota front brakes, sheet metal fan shroud, spin on filter, plastic trans cover and more. Always garaged and covered since 1977 when I bought it. SCTOA member since 1986. \$21,500

Barry Norman 310-625-7937
fogerty@aol.com



1962 TR3B Must sell due to health issues. Partially restored and has the original driveline totally rebuilt. New interior/top/side screens/etc. Some work still needed to make show ready. Lots of extras. With receipts and original plate. \$15,000

Bill 909-866-6777; mrmeter@charter.net



Car Cover 1979 Spitfire. Rainproof, Has one little hole for radio antenna. Likely fits most Spitfires or other small Triumphs. Cost \$149 new; keeps out 95% of rain. It's used but in good shape. It's used but in good shape. Asking \$35

Portable hard top carrier. Homemade. This will fit the hard top for a 1979 Spitfire, has great rollers, is lightweight and works perfectly. Asking \$25.

David 562-243-0127 dross4646@yahoo.com



TR3 Steel Wheels 5 TR2-3-4 steel wheels. Need cleaned-up and painted. **Free.**

Norm 949-466-4599

NoermTR3Search@cox.net

1967 TR4A with surrey top. Ford 302 with Trick Flow heads, Edelbrock intake, Holley 650 DP, Engle cam, Mallory distributor, MSD ignition. Coated headers and stainless exhaust. Tremec 5 speed. Ford 8 inch rear with positraction and 3.55 gears. Steve has been a member of SCTOA for many years; due to poor health he had to stop his activity with the club which he thoroughly enjoyed. Very quick. \$18,000/OBO.

Cheryl McElliott: Home 760-325-5254, Cell 310-710-7484; cherylmcellriott@hotmail.com



For Sale: Because of the untimely passing of our friend **Loren Wood**, there are some items that need to be sold. If interested in the items below, please contact Bo Marron – trspitfire1@hotmail.com. Collected money will go to Loren's wife, **Malinda Wood**.



1974 TR6. Brown Starting at \$22,000. New soft top, over drive transmission, many extras



2012 Mazda MX5 (Miata) \$14K 67,840 mi



"boat" (canoe) – Make offer

1972 Stag, Red, wire wheels, hardtop, org. soft top. Org. 3L engine w/automatic. 47K miles

1980 TR7 2-tone Gold/Silver. 5-speed. New Tan top. 50K miles

Make offer for both. Many spares and accessories. Call or email for info.

Gordy Hite 949-951-7588

grumpagh@hotmail.com



Morgan
WEST
Authorized Morgan Motor Car Dealer

ORDER YOURS IMMEDIATELY! (310) 998-3311

2010 Morgan Aero SuperSports

Only 150-200 to be built for the world, ever! The absolutely stunning new U.S. legal 2010 Morgan Aero SuperSports. It is certainly one of the most beautiful, sensuous new cars ever designed and offered by any manufacturer at any time. It is, quite simply, breathtaking to behold, breathtaking to drive.



WWW.MORGANWEST.NET

Commemorate 100 Years of Morgan with a limited edition badge made of the very finest enamels, cloissene and chrome. \$145+ shipping. Contact: Suzanne@morganwest.net



2007 MORGAN AERO 8 Blue Sprint Metallic

- Featured in the SuperCar Class at The Quail

2005 MORGAN AERO 8

Silver Shark/blue leather. Very late 2005 10K one owner miles.

2005 AERO 8 BMW

Cool Blue exterior Magnolia leather w/ blue piping, 8K miles

'03 PLUS 8 35th Edition

Dark Jaguar Blue

'03 PLUS 8 35th Edition

Ivory/Black, 5.7k

'03 PLUS 8 35th Edition

6650 miles, Red

'02 PLUS 8 BMW Imola

Red 3.8k miles

'98 PLUS 8

Cameron Green/Black leather 13k original miles. 4.0 litre, GEMS injection!

'64 PLUS 4 Raspberry,

Brown Leather, Alloy low profile SS body, 167 dyno'ed HP

'61 +4 Four Passenger Family Tourer

Red/ black

'54 PLUS 4 Roadster

Twin Spare Beige

'34 MX FAMILY TRIKE

Matchless engine

'33 JAP SUPER

SPORT Trike Pozzi Blue, **REDUCED!**

other marques

'74 PORSCHE 911 Carrera Targa

'66 AUSTIN-HEALEY 3000 Mrk III

'65 AUSTIN-HEALEY 3000 Mrk III

'57 PORSCHE Speedster Custom



WWW.ALLARDWEST.COM

WWW.ZOLFEWEST.COM

Dennis@MorganWest.Net — Managing Director 3003 Pico Boulevard, Santa Monica, CA 90405



- SERVICE • REPAIR
- RESTORATION • PARTS
- CONSIGNMENT SALES

Bernie Sloan

1525 S. Pacific Avenue
San Pedro CA 90731
(310) 833-1525
Fax 833-7985

www.BritishCarLA.com
e-mail: Bernie@BritishCarLA.com

HVDA

**TOYOTA TO TRIUMPH
5-Speed Transmission
Conversions
TR-2 through TR-6**

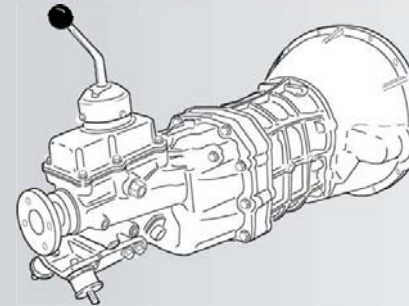

Herman van den Akker
P.O. Box 6812
Pine Mountain Club, CA 93222
Phone: (661) 242-1253
E-mail: handhvan@msn.com
www.hvdaconversions.com

Barlow Insurance

Quality Collector Car Insurance *Since 1971*

JONATHAN BARLOW

Lic#CA0774014

800-558-7772 • 951-279-4002 • Fax 951-279-8502
P.O. Box 77788 • Corona, CA 92877-0126
barlowjb@pacbell.net

Please Visit our Website at

www.BarlowInsurance.net



**CLASSIC AUTO RESTORATION & REPAIR
BRITISH PARTS DISTRIBUTOR**

WWW.UNIONJACK.COM
13555 Depot St. PO Box 551 San Martin, CA 95046
408 686-1101 Fax 683-2447



**We are a Restoration
and Modification
Shop Specializing
in Triumphs
and MGB's.**

Chevy 3400/3500 V6

- Engine Swap
- 5 Speed or Automatic

Transmission Swap

- TR 3, 4, 6
- Ford T5's

Fuel Injection

- Wiring Harness
- Electric Power Steering
- ECM Reprogramming

BritishRestorations@telus.net

Bill Sinclair / (250) 868-0408

Follow our projects on Facebook

Dave Renner / (250) 878-7730

INSURANCE CENTER ASSOCIATES



Michael Leone – Collector Car Specialist

1622 S. Gaffey • PO Box 671
San Pedro, CA 90733-0671
tel: (800) 649-3101
fax: (310) 832-8024

Multiple Carriers • Local Personalized Agent • Add Newer Cars!

Michael Leone

Lic: 0203423

E-Mail: mleone@inscenter.com

Phone: 310-832-5311 x232

Monthly Events

Belmont Shore British Car Night

First Wednesday of Every Month

6-8 pm. Drive your pre-1980 British car to the Belmont Brewing Company between Park on the West side of the Belmont Shore Olympic Pool.

Contact: Tim Clark at babula@peoplepc.com

Inland Empire Breakfast Group

Third Saturday of Every Month

8:00 am. Meet in Polly's Pies, 1799 Hamner Ave, Norco, CA 92680 at Hamner and Second St. of the 15 Hwy north of the 91 Fwy.

Talk about your Triumph, your actives and what is happening with the clubs.

Contact: Rob Bowen, bowen6951@yahoo.com.

San Fernando Valley Breakfast Group

First & Third Saturday of Every Month

9:00 am, Meet at Bob's Big Boy, 4211 West Riverside Drive, Burbank, CA. After breakfast, the group moves to the parking lot for the traditional tire kicking, bonnet raising, Triumph tales and frequent "Mini Tech Sessions."

Directions:

From the East; Exit the 134 Freeway at the Hollywood Way exit, turn left on Alameda Avenue, which merges with Riverside Drive after five blocks, Bob's Big Boy is on the right [North] side.

From the West; Exit the 134 Freeway at Pass Avenue, turn right and drive one block to Alameda Avenue. Turn right [West] on Alameda which merges with Riverside Drive in one block. Bob's Big Boy is on the right [North] side.

Contact: Dale Berman at Dalebermanphoto@earthlink.net, 818-841-0200

Orange County Breakfast Group

Second Saturday of Every Month

1) 6:00 am or earlier: "Car Show" at the Enderle Center of Tustin. N/W portion of the Center's parking lots, cross streets 17th & Yorba, 1/2 block East of SR 55 Fwy.

2) 8:00 am: Caravan to breakfast via non-freeway roads that will test TR's.

3) 9:00 Breakfast at Two's Company, #22 on the Traffic Circle at Chapman & Glassel in Orange* Plenty of TR parking in the lot south of the Drug Store.

Contact: John Gladysiewicz mijig@aol.com

* Note if you don't see us while going around the Traffic Circle, we will be At Blue Frog, # 136 Glassel in Orange because TWO's Company may not have opened yet. We still park in the lot behind the Army-Navy Store for both breakfast.

Golden Cove British Car Meet

Third Sunday of Every Month

Gathering of LBC's (Little British Cars) of all Marques. Ocean view parking lot. Cars show up by 9:00 am.

Visit our award winning website: <http://www.sctoa.org>

Calendar of Events

Look here for more events each month

visit <http://web.mac.com/sctoa> to view the calendar

October

- 10 **TCSC Club Meeting and Food Drive**
- 14 ~~Car Hop Night at Bob's Big Boy~~ - Cancelled
Dale Berman 818 841-0200 daleberman-photo@earthlink.net
- 14 El Monte Christmas Parade -
Cody Crowley 626 340-8617 codyccrowley@gmail.com
- 15 Pomona Swap Meet and Classic Car Show
- 21 ~~Falling Leaf Drive (FRSC)~~ - Cancelled
Bob Muzio (818) 703-1846, trjag@yahoo.com
- 28 Halloween Party - Patti & Carl Miller 562 576-2630
cmiller1948@charter.net

November

- 4-5 Julian Drive Rob & Bonny Bowen RSVP bowen6951@yahoo.com
- 5 Teddy Bear Run, Ventura
- 14 **TCSC Club Meeting**
- 21 LaBrea Tar Pits - John Roberts, (310)-384-8491, scouse2@aol.com

December

- 2 TCSC Christmas Party at TBD
- 3 Pomona Swap Meet
- 9 Planning Meeting
- 12 **TCSC Club Meeting**

January

- 1 New Year's Day Drive, Robert Tyler, details TBD. RSVP 661 298-1405 or email: rt Tyler@socal.rr.com
- 9 **TCSC Club Meeting**
- 17 William Lyon Museum,- John Roberts, (310)-384-8491, scouse2@aol.com

February

- 3 San Juan Capistrano Car Show,
RSVP Gary Hunt: 949 632-3520 sportsallday24@hotmail.com
- 13 **TCSC Club Meeting**

March

- 13 **TCSC Club Meeting**

April

- 10 **TCSC Club Meeting**
- 21 Queen's English All British Car Meet, 626 797-4221.
Pre-register:www.queens-english.org

May

- 8 **TCSC Club Meeting**
- 5 Antique Crawl in Ol' Town Orange -
Kate McKee (714)814-9485 K8mckee@yahoo.com

June

- 4 Pomona Swap Meet and Classic Car Show
- 12 **TCSC Club Meeting**
- 8-10 Cambria Blow-Out Rally - Cambria Tour

July

- 10 **TCSC Club Meeting & White Elephant Sale (special night)**
- 15 CCBCC Channel Island Car Show, Oxnard
- 21 Crystal Cove Picnic, Laguna Beach -
Kate McKee (714)814-9485 K8mckee@yahoo.com

August

- 14 **TCSC Club Meeting**
- TBD VTR National Convention at Princeton, NJ - <http://vtr2017.org/>

September

- 11 **TCSC Club Meeting**
- TBD Triumphest Flagstaff, AZ - <http://www.triumphest.com/>

Event Sponsors Wanted

SCTOA is looking for volunteers to sponsor an event such as a driving tour, tech clinic, local event/BBQ, or other imaginative event.

New events will be given priority dates over existing events at the next planning meeting.

Contact John Roberts at scouse2@aol.com or 310-384-8491



SOUTHERN CALIFORNIA TRIUMPH OWNERS ASSOCIATION

P.O. Box 83820, Los Angeles, CA 90083

SCTOA is the nation's largest VTR chapter..

SCTOA would like to count you in on the fun.

Contact a club member, or attend an event.



Visit our award winning website: www.sctoa.org

FIRST NAME	_____	MEMBERSHIP
LAST NAME	_____	<input type="checkbox"/> SCTOA
SPOUSE/CO-DRIVER	_____	<input type="checkbox"/> TRSC
STREET	_____	<input type="checkbox"/> VTR
CITY	_____	<input type="checkbox"/> Other TR Club
STATE	_____ ZIP _____	<input type="checkbox"/> Advertiser
H PHONE	_____	COMMENTS
W PHONE	_____	_____
CELL PHONE	_____	_____
E-MAIL	_____	_____
ALTERNATE E-MAIL	_____	_____
OCCUPATION	_____	_____
SKILLS/INTERESTS	_____	_____
ACTIVITIES ENJOYED	<input type="checkbox"/> SHOWS <input type="checkbox"/> RALLYE <input type="checkbox"/> TECH SESSIONS	_____
OTHER-PLEASE SPECIFY	_____	_____
YEAR/MODEL CAR 1	_____	_____
COLOR CAR 1	_____	_____
CONDITION CAR 1	_____	_____
EXTRAS, CAR 1	_____	_____
COMMISSION # CAR 1	_____	_____
YEAR/MODEL CAR 2	_____	_____
COLOR CAR 2	_____	_____
CONDITION CAR 2	_____	REFERRED BY
EXTRAS, CAR 2	_____	_____
COMMISSION # CAR 2	_____	_____
OTHER VINTAGE CARS	_____	_____

DO NOT PUBLISH MY CONTACT INFORMATION IN THE MEMBERSHIP ROSTER

ANNUAL DUES: \$35 USA \$40 Foreign

Make your check payable to: SCTOA, P.O. Box 83820, Los Angeles, CA 90083

There are no conditions or requirements for membership to SCTOA. The information on the membership form will be used to better serve the needs of SCTOA members and sponsors. All information is optional and will never be sold or given away for commercial use. Membership information is published in a yearly roster and distributed to all SCTOA members. You may request that this information be withheld, by checking the box above, per the Privacy Act of 1974.



THIS IS WHO WE ARE



DELIVERING QUALITY SINCE 1948

David Williams
R & D Shop Supervisor
ASE Master Technician
Moss employee since 2005

David Aidnik
Chief Engineer
Moss employee since 2013

Mike Vickers
Product Quality
Assurance Supervisor
Moss employee since 1986

We take pride in being fussy. Take our Classic Gold brake shoes for example. Before being called Classic Gold, we improved the original stock design, then had them manufactured, inspected, trial fitted and tested on the road. Accept nothing less than the best. We don't.

SAME DAY SHIPPING FREE CATALOGS TECH SUPPORT EAST & WEST COAST WAREHOUSES



800-667-7872
MossMotors.com

The SCTOATRSC club meeting is held on the **SECOND TUESDAY OF EACH MONTH.** @ 7:30 p.m. at: **Geezers, 12120 Telegraph Rd, Santa Fe Springs**

Regional Breakfast Groups

Please check with your area's chairperson for the location, time, & date.
(Their numbers are on the inside of the cover.)

Hey everybody...

Please check your expiration date. It's right there on your mailing label.

If this date is past, then your dues are due. Make your check payable to:

SCTOA, P.O. Box 83820, Los Angeles, CA 90083



Coming Soon, Mark Your Calendar:

October

- 10 TCSC Club Meeting
- 14 El Monte Christmas Parade
- 15 Pomona Swap Meet and Classic Car Show
- 28 Halloween Party

November

- 4-5 Julian Drive
- 5 Teddy Bear Run, Ventura
- 14 TCSC Club Meeting
- 21 Labrea Tar Pits

December

- 2 TCSC Christmas Party

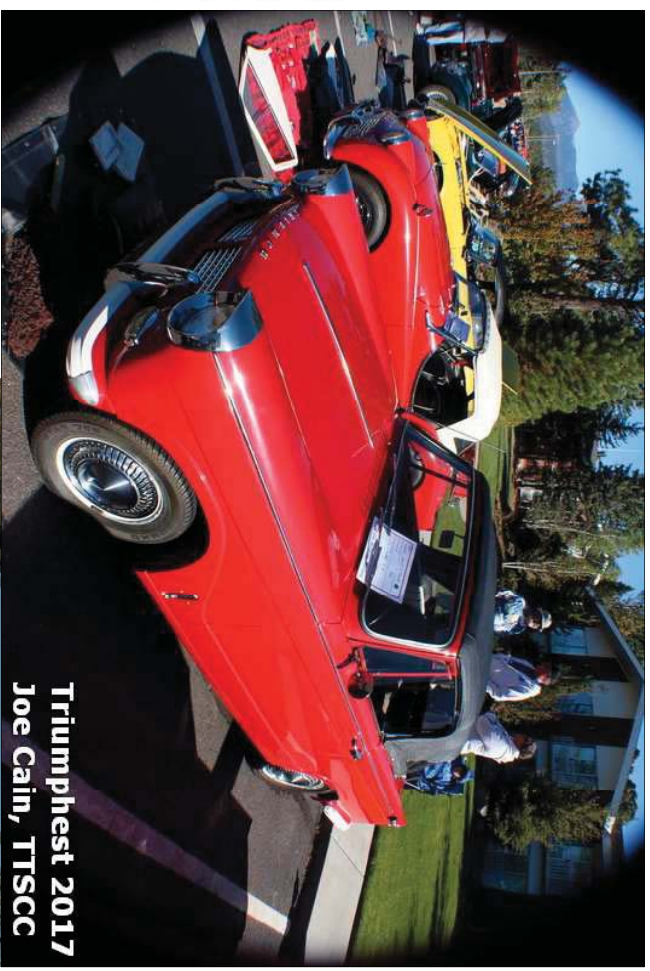

**Triumphest 2017
Joe Cain, TTSCC**

A few pictures of Steve Hedke's Herald and TR3A on display at Triumphest 2017 in Flagstaff. Steve was able to purchase these fine Triumphs from their original owners.



Photo by Janet Hedke